



ROBUST LIFTING FOR DYNAMIC WORK ENVIRONMENTS

- DKK JIB CRANES ARE VITAL TO ANY PRODUCTION PROCESS REQUIRING SPEED, ACCURACY, AND MINIMAL DOWNTIME. DESIGNED FOR A SEAMLESS USER EXPERIENCE, THEY ARE VERSATILE, DURABLE, AND SERVE ALMOST ANY KIND OF WORKSTATION, PROVIDING SUPPORT FOR OVERHEAD CRANES ON PRODUCTION LINES, AND HELPING TO KEEP TERMINALS, MACHINING CELLS, AND WAREHOUSES OPERATING SMOOTHLY.

WITH SEVERAL DIFFERENT WAYS TO FIX THE JIB TO THE WALL OR FLOOR, AND A VARIETY OF HOISTS AVAILABLE, THEY ARE PERFECTLY SUITED TO MOST CUSTOMER FACILITIES. THE CRANES HAVE A LOAD CAPACITY OF UP TO 2,000 KG AND A SLEWING MOTION THAT CAN REACH 300 DEGREES WITH A PILLAR JIB, AND 270 DEGREES WITH A WALL MOUNTED JIB.

- THE DKK WALL-MOUNTED AND PILLAR JIB CRANES HAVE COMMON PRODUCT FEATURES, INCLUDING:

DKK SERVICES



Standard features	Pillar-mounted Jib crane	Wall-mounted Jib crane
Lifting capacity	3,000 kg	2,000 kg
Crane control	Radio / pendant	Radio / pendant
Maximum rotation	360°/270°	270°
Hoist options	Manual hoist, electric chain hoist, air balancer	Manual hoist, electric chain hoist, air balancer
EC Machinery Directive		
Humidity	Maximum 80 % relative humidity	Maximum 80 % relative humidity
Ambient temperature*	-20 °C to +70 °C	-20 °C to +70 °C
Surface protection and paint**	Category C2-M corrosion protection according to DIN EN ISO 12944	Category C2-M corrosion protection according to DIN EN ISO 12944

JIB CRANE

DKK SERVICES

- • MULTIPLE DESIGNS FOR JIB ARMS BASED ON CUSTOMER REQUIREMENTS
- STEADY SLEWING WITH ROBUST BEARING AND ADJUSTABLE SLEWING RESISTANCE
- MANUAL SLEWING AVAILABLE FOR ALL TYPES
- SLEWING LIMITER ALLOWS ROTATION ADJUSTMENT EVERY TWO DEGREES
- CLAMP FITTING LETS SLEWING LIMITER BE ADDED AFTER INSTALLATION
- MOTORIZED SLEWING FOR JIBS WITH I-BEAM ARMS
- STANDARD ON/OFF SAFETY SWITCH WITH PILLAR JIBS (OPTIONAL FOR WALL-MOUNTED)
- ROBUST FESTOONING AND EASY RUNNING WITH RELIABLE CABLE CARRIERS
- PILLAR-MOUNTED JIBS ALLOW CABLES FROM BELOW, SIDE, OR ABOVE
- SELECTION OF HOISTS: MANUAL, ELECTRIC CHAIN, AND PNEUMATIC LIFTING DEVICES

- * APPLIES TO THE JIB CRANE STEEL STRUCTURE ONLY. OTHER COMPONENTS SUCH AS DIFFERENT HOIST TYPES HAVE MORE NARROW OPERATING CONDITIONS.
** HIGHER-GRADE PROTECTIVE PAINT OR OTHER PAINT COLOURS ON REQUEST

- DKK JIB CRANES ARE FAST AND PRECISE TOOLS FOR MATERIAL HANDLING WITH THE FOLLOWING PRODUCT BENEFITS:
 - EASILY ADAPTS TO YOUR MULTIPURPOSE FACILITY WITH A WIDE RANGE OF OPTIONS
 - IMPROVES SAFETY AND PRODUCTIVITY
 - EFFICIENT AND ACCURATE LOAD HANDLING UP TO 2,000 KG
 - ADVANCED ERGONOMIC DESIGN AND ADJUSTABLE FEATURES ENHANCE THE OPERATOR EXPERIENCE
 - SIMPLE TO INSTALL AND RELOCATE

DKK SERVICES

Dkk Introduces An Adjustable console bearing for Jib crane as a standard product feature this makes beam adjustment extremely easy and accurate improving significantly the usability of the crane competing with existing jib crane products market

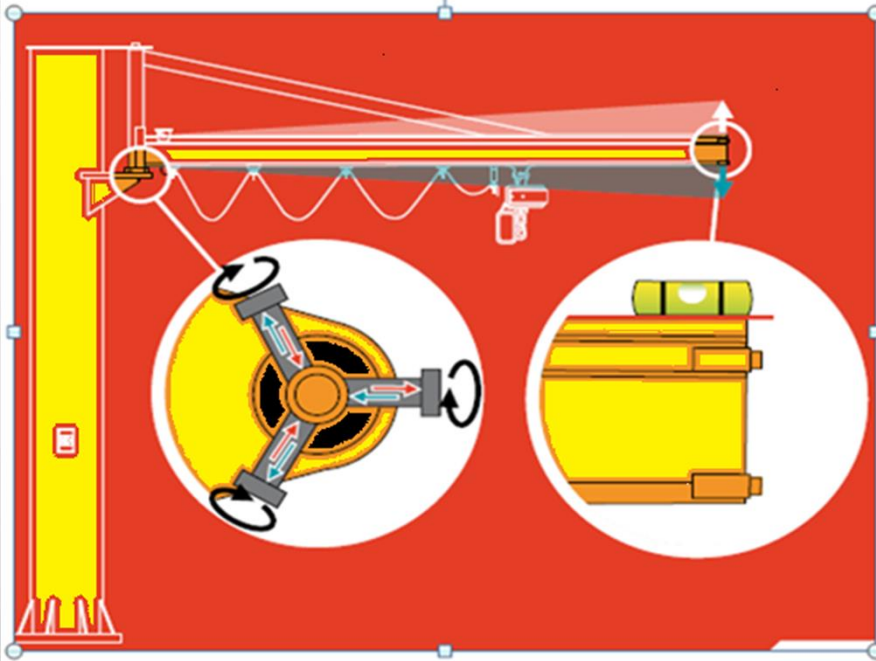

Increased Safety : Uncontrolled Trolley And Jib Beam Movement As Minimized With Simple And easy Adjustment

Short Downtime : Installation And Possible Relocation Of jib crane can Be done Quickly And Easily Reducing Production Down time

DKK SERVICES

PILLAR AND WALL MOUNTING JIB CRANE I SECTION TYPE

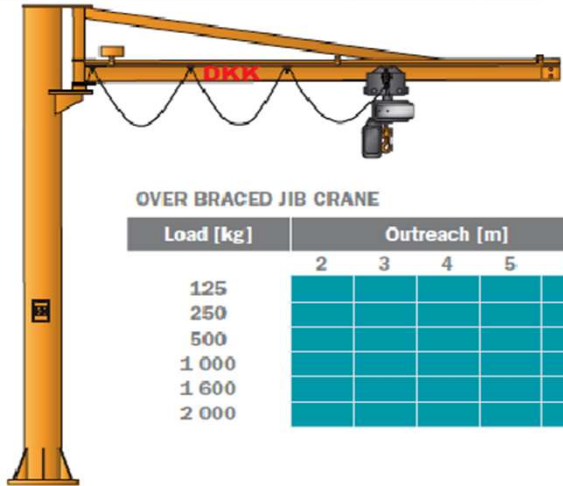

OVER BRACED JIB CRANE

Load [kg]	Outreach [m]				
	2	3	4	5	6
125					
250					
500					
1 000					
1 600					
2 000					



OVER BRACED JIB CRANE

Load [kg]	Outreach [m]				
	2	3	4	5	6
125					
250					
500					
1 000					
1 600					
2 000					

DKK SERVICES

HAMMER TYPE JIB CRANE FOR LOW HEIGHT LIFTING

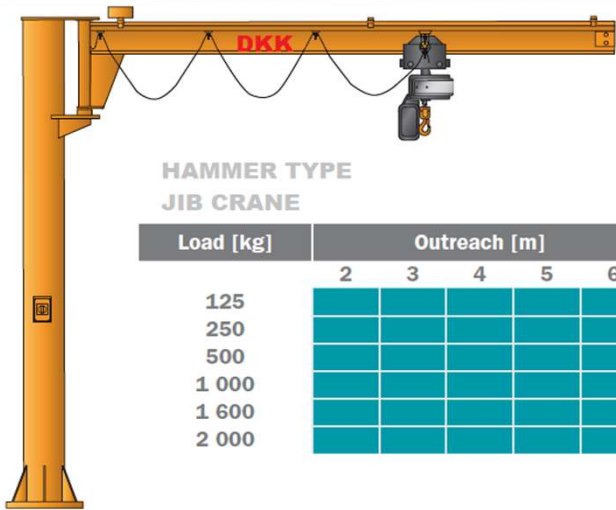

**HAMMER TYPE
JIB CRANE**

Load [kg]	Outreach [m]				
	2	3	4	5	6
125					
250					
500					
1 000					
1 600					
2 000					



**Wall Mounting
JIB CRANE**

Load [kg]	Outreach [m]				
	2	3	4	5	6
125					
250					
500					
1 000					
1 600					
2 000					

DKK SERVICES

KBK RAIL TYPE JIB CRANE

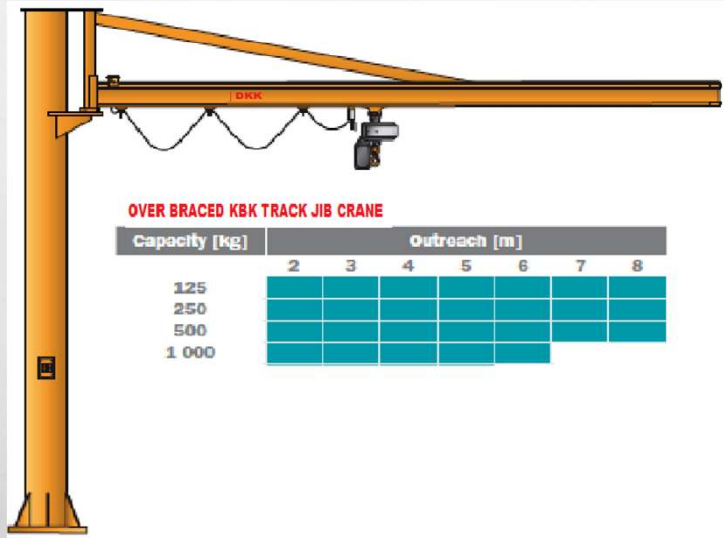

OVER BRACED KBK TRACK JIB CRANE

Capacity [kg]	Outreach [m]							
	2	3	4	5	6	7	8	
125								
250								
500								
1 000								

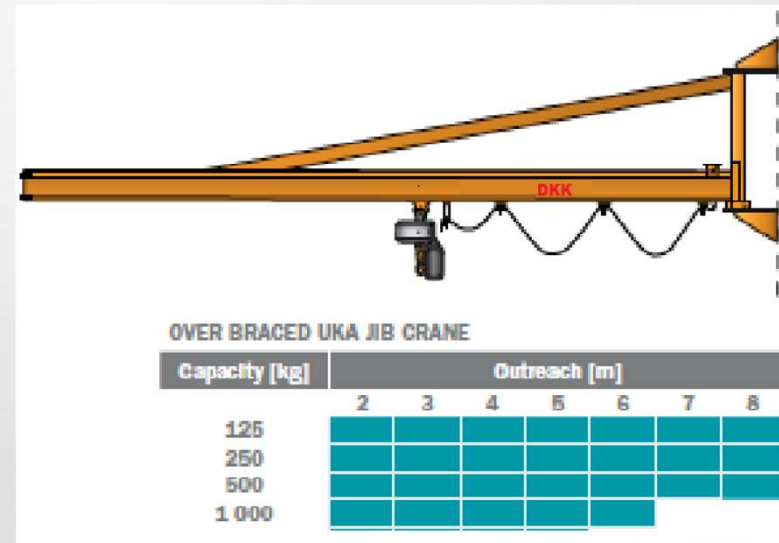

OVER BRACED UKA JIB CRANE

Capacity [kg]	Outreach [m]							
	2	3	4	5	6	7	8	
125								
250								
500								
1 000								

JIB CRANE



DKK SERVICES

360 DEG ROTATION JIB CRANE



360° Electrical Rotating Column Jib Cranes for Sale
CRANES Electrically Rotated series jibs are ideal for handling high or bulky loads, and it's extremely rigid with a solid base plate.
This electrical rotating [jib crane](#) does not allow for manual handling, and it's ideal for outdoor squares, deposits, loading ramps and on wharves.
This model is available for lifting loads from 500kg to 32,000kg, and we can guide you through each of its



DKK SERVICES

PRODUCTS RANGE: 500 kg to 3.2 ton	
Product Name	Jib Crane 360 Degree Rotation Motorized and Manual
Application	Machine Shop and Foundry application (also use for heavy product lifting)
Material	IS 2062
Welding Type	CO2 and Arc
Lifting Weight	125kg to 3.2 ton capacity
Self Weight	500kg to 1.5ton (approx) its majorly depends on designs and situations
Life of Product	8 to 10 years
Motor	Depend on customer demands
Electric	yes
Max span	6 Mtr
Maintenance	Easy to repair
Phase of Electricity	3- phase
Capacity	125kg to 3.2ton capacity

DKK SERVICES



OUR VALVABLE CUSTOMAR



DKK SERVICES